

# Intel® X25-E SATA Solid State Drive

*SSDSA2SH032G1*

## Advance Product Manual

- Available in 2.5" Form Factor
- Capacity: 32 GB
- Uses Intel NAND flash memory Single Level Cell (SLC) components
- Bandwidth Performance Specifications
  - Sustained Sequential Read: Upto 250 MB/s
  - Sustained Sequential Write: Upto 170 MB/s
- Read and Write IOPS Specifications (IOMeter Queue Depth 32)
  - Random 4 KB Reads: 35 K IOPS
  - Random 4 KB Writes: 3.3 K IOPS
  - Random 8 KB 2:1 Reads/Writes: 7K IOPS
- Compatibility
  - Intel® Matrix Storage Manager
  - SATA Revision 2.6 compliant, compatible with SATA 1.5 Gb/s and 3 Gb/s interface rates
  - ATA/ATAPI-7 Compliant
  - SSD Enhanced SMART ATA feature set
  - Native Command Queuing (NCQ) command
- Compliance
  - UL\*
  - CE\*
  - C-Tick\*
  - BSMI\*
  - MIC\*
  - Microsoft\* WHQL
  - RoHS\*
- Power Management
  - 5 V SATA Supply Rail
  - Supports ATA Power Management and Advanced Power Management Specifications
  - SATA Interface Power Management
  - OS-Aware Hot Plug/Removal
- Power Specifications
  - Active: 2.4 W TYP
  - Idle: .060 W TYP
- Temperature
  - Operating: 0° C to 70° C
  - Non-Operating: -55° C to 95° C
- Reliability
  - Bit Error Rate (BER): 1 sector per 10<sup>15</sup> bits read
  - Mean Time Between Failures (MTBF) 2,000,000 Hours
- Shock
  - Operating and Non-operating: 1,000G/0.5 msec
- Vibration
  - Operating: 2.17 G (7-800 Hz)
  - Non-operating 3.13 G (10-500 Hz)
- Weight: 80 +/- 2 grams (2.5" 7 mm Form Factor)



## Ordering Information

### Decoder

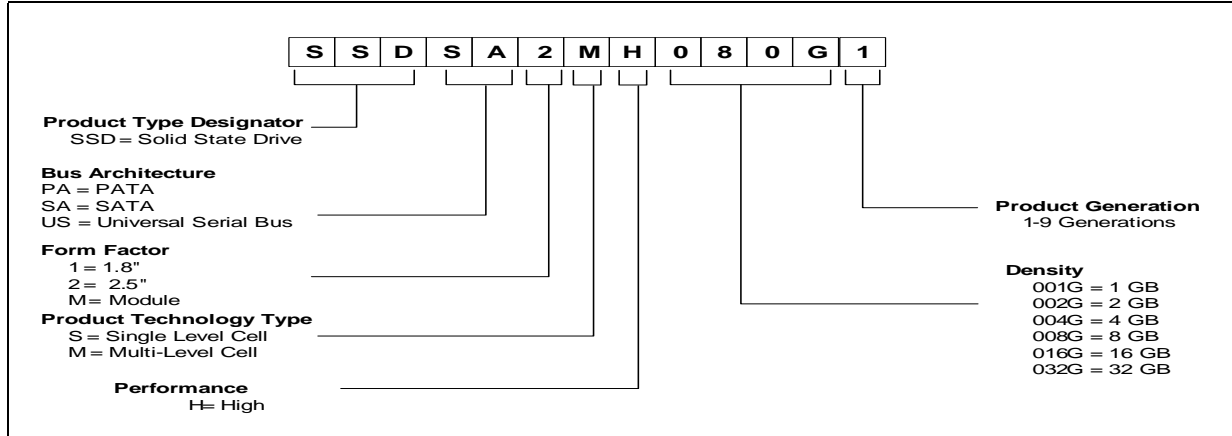

### Intel High Performance Solid State Drive Ordering Information

Part Number	MM #	Device Nomenclature	Packaging
SSDSA2SH032G1	894466	32 GB SATA 2.5" Drive SLC High Performance, Qualification Sample	1 unit

INFORMATION IN THIS DOCUMENT IS PROVIDED IN CONNECTION WITH INTEL® PRODUCTS. NO LICENSE, EXPRESS OR IMPLIED, BY ESTOPPEL OR OTHERWISE, TO ANY INTELLECTUAL PROPERTY RIGHTS IS GRANTED BY THIS DOCUMENT. EXCEPT AS PROVIDED IN INTEL'S TERMS AND CONDITIONS OF SALE FOR SUCH PRODUCTS, INTEL ASSUMES NO LIABILITY WHATSOEVER, AND INTEL DISCLAIMS ANY EXPRESS OR IMPLIED WARRANTY, RELATING TO SALE AND/OR USE OF INTEL PRODUCTS INCLUDING LIABILITY OR WARRANTIES RELATING TO FITNESS FOR A PARTICULAR PURPOSE, MERCHANTABILITY, OR INFRINGEMENT OF ANY PATENT, COPYRIGHT OR OTHER INTELLECTUAL PROPERTY RIGHT. Intel products are not intended for use in medical, life saving, life sustaining, critical control or safety systems, or in nuclear facility applications.

Intel may make changes to specifications and product descriptions at any time, without notice.

Intel Corporation may have patents or pending patent applications, trademarks, copyrights, or other intellectual property rights that relate to the presented subject matter. The furnishing of documents and other materials and information does not provide any license, express or implied, by estoppel or otherwise, to any such patents, trademarks, copyrights, or other intellectual property rights.

**IMPORTANT - PLEASE READ BEFORE INSTALLING OR USING INTEL® PRE-RELEASE PRODUCTS.**

Please review the terms at [http://www.intel.com/netcomms/prerelease\\_terms.htm](http://www.intel.com/netcomms/prerelease_terms.htm) carefully before using any Intel® pre-release product, including any evaluation, development or reference hardware and/or software product (collectively, "Pre-Release Product"). By using the Pre-Release Product, you indicate your acceptance of these terms, which constitute the agreement (the "Agreement") between you and Intel Corporation ("Intel"). In the event that you do not agree with any of these terms and conditions, do not use or install the Pre-Release Product and promptly return it unused to Intel.

Designers must not rely on the absence or characteristics of any features or instructions marked "reserved" or "undefined." Intel reserves these for future definition and shall have no responsibility whatsoever for conflicts or incompatibilities arising from future changes to them.

This document contains information on products in the design phase of development. The information here is subject to change without notice. Do not finalize a design with this information.

This Advance Product Manual as well as the software described in it is furnished under license and may only be used or copied in accordance with the terms of the license. The information in this manual is furnished for informational use only, is subject to change without notice, and should not be construed as a commitment by Intel Corporation. Intel Corporation assumes no responsibility or liability for any errors or inaccuracies that may appear in this document or any software that may be provided in association with this document.

Except as permitted by such license, no part of this document may be reproduced, stored in a retrieval system, or transmitted in any form or by any means without the express written consent of Intel Corporation.

Contact your local Intel sales office or your distributor to obtain the latest specifications and before placing your product order.

Copies of documents which have an order number and are referenced in this document, or other Intel literature may be obtained by calling 1-800-548-4725 or by visiting Intel's website at <http://www.intel.com>.

\*Other names and brands may be claimed as the property of others. Copyright © 2008, Intel Corporation. All Rights Reserved.

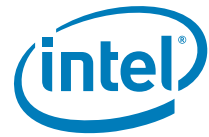

## Contents

---

<b>1.0</b>	<b>Introduction</b>	5
1.1	Product Overview	5
1.2	Block Diagram	6
1.3	Architecture	6
<b>2.0</b>	<b>Certifications and Compliance</b>	7
<b>3.0</b>	<b>Product Specifications</b>	7
3.1	Capacity	7
3.2	Performance	7
3.3	Electrical Characteristics	8
3.3.1	Supply Voltage	8
3.3.2	Power Consumption	8
3.4	Environmental Conditions	9
3.4.1	Temperature	9
3.4.2	Altitude	9
3.4.3	Shock and Vibration	9
3.4.4	Acoustics	10
3.4.5	Electromagnetic Immunity	10
3.5	Reliability	10
3.5.1	Non-recoverable read errors	11
3.5.2	Mean Time Between Failure	11
3.5.3	Power On/Off Cycles	11
<b>4.0</b>	<b>Mechanical Information</b>	12
<b>5.0</b>	<b>Pin and Signal Descriptions</b>	13
5.1	Pin Locations	13
5.2	Signal Description Table	13
5.3	Hot Plug Support	14
<b>6.0</b>	<b>Command Sets</b>	15
6.1	ATA Commands	15
6.1.1	ATA General Feature Command Set	15
6.1.2	Power Management Command Set	18
6.1.3	Security Mode Feature Set	18
6.1.4	SMART Command Set	19
6.1.5	Host Protected Area Command Set	19
6.1.6	48-Bit Address Command Set	19
6.1.7	Device Configuration Overlay Command Set	20
6.1.8	General Purpose Log Command Set	20
6.2	SATA Commands	20
6.2.1	Software Settings Preservation	20
6.2.2	Native Command Queuing	20
<b>7.0</b>	<b>References</b>	21
<b>8.0</b>	<b>Glossary</b>	22
<b>9.0</b>	<b>Revision History</b>	23

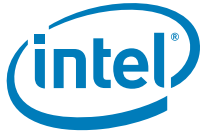

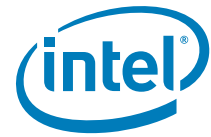

## 1.0 Introduction

The Intel® X25-E SATA Solid State Drive (SSD) delivers ultimate performance in an industry standard 2.5" form factor while simultaneously improving system responsiveness over standard rotating media or hard disk drives (HDD) in some of the most demanding applications. By combining Intel's leading NAND flash memory technology with our innovative controller, Intel delivers an SSD for Native Serial Advanced Technology Attachment (SATA) hard disk drive drop-in replacement with enhanced performance, reliability, ruggedness and power savings.

Since there are no rotating platters, moving heads, fragile actuators, unnecessary spin-up time or positional seek time that can significantly slow down the storage subsystem, the Intel X25-E SATA SSD enables fast read/write access times and significant I/O, as well as performance improvement when compared to rotating media.

This document describes the specifications of the Intel X25-E SATA SSD in the 2.5" form factor.

## 1.1 Product Overview

The Intel X25-E SATA SSD primarily targets high-end workstations, desktops, gaming and various server/storage applications. Key attributes include extremely high performance, low power, enhanced reliability and improved ruggedness as compared to standard 10,000 and 15,000 RPM SATA hard drives. The Intel X25-E SATA SSD is available in an industry standard 2.5" form factor that is electronically, mechanically, and software compatible with existing SATA and Serial Attached SCSI (SAS) slots and cables.

## 1.2 Block Diagram

Figure 1. Block Diagram

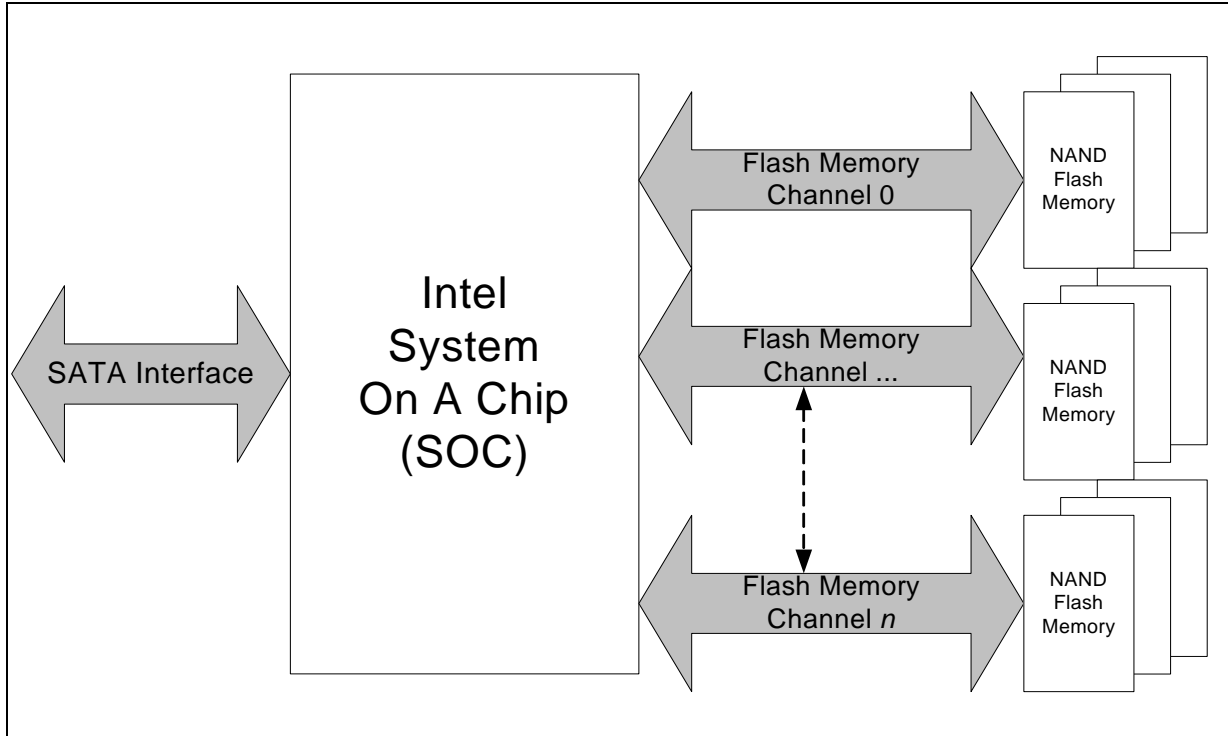

## 1.3 Architecture

The Intel® X25-E SATA Solid State Drives utilize a cost effective System on a Chip (SOC) design to manage a full SATA 3 Gb/s bandwidth with the host while managing multiple flash memory devices on multiple channels internally.



## 2.0 Certifications and Compliance

**Table 1. Device Certifications**

Certification/Compliance	Description
CE Compliant	Indicate conformity with the essential health and safety requirements set out in European Directives Low Voltage Directive and EMC directive.
UL Certified	Underwriters Laboratories, Inc. Component Recognition UL60950-1.
C-Tick Compliant	Compliance with EN 55022:2006 and the Electromagnetic Compatibility (EMC) Framework requirements of the Australian Communication Authority (ACA).
BSMI Compliant	Compliance to the Taiwan EMC standard "Limits and methods of measurement of radio disturbance characteristics of information technology equipment, CNS 13438 Class B."
MIC Certified	Compliance with paragraph 1 of Article 11 of the Electromagnetic Compatibility control Regulation and meet the Electromagnetic Compatibility (EMC) Framework requirements of the Radio Research Laboratory (RRL) Ministry of Information and Communication Republic of Korea.
Microsoft WHQL Certified	Microsoft Windows Hardware Quality Labs
RoHS Compliant	Restriction of Hazardous Substance Directive

## 3.0 Product Specifications

### 3.1 Capacity

**Table 2. User Addressable Sectors**

Unformatted Capacity	Total User Addressable Sectors in LBA Mode
32 GB	62,500,000

**Notes:**

- 1GB = 1,000,000,000Byte and not all of the memory can not be used for data storage.
- 1 sector = 512 Byte

### 3.2 Performance

**Table 3. Maximum Sustained Read and Write Bandwidth**

Access Type	MB/s
Sequential Read	Upto 250
Sequential Write	Upto 170

**Notes:**

1. Performance measured using IOMeter with queue depth set to 32.
2. Write Cache enabled.



**Table 4. Random Read and Write Input/Output Operations per Second (IOPS)**

Access Type	IOPS
4K Read	35,000
4K Write	3,300
8K 2:1 Read:Write	7,000

**Notes:**

1. Performance measured using IOmeter with queue depth set to 32.
2. Write Cache enabled.
3. Random IOPS cover the entire range of legal logical block addresses (LBAs). Measurements are performed on a full drive (all LBAs have valid content).

**Table 5. Latency Specifications**

Type	Average Latency
Read	75 µs (TYP)
Write	85 µs (TYP)
Power On to Ready	1 s

**Notes:**

1. Write Cache enabled.
2. Device measured using IOmeter\*.
3. Power On to Ready (POR) time assumes proper shutdown (power removal preceded by STANDBY command).
4. Read/Write latency measured on 4 k transfers.
5. Queue depth set to 1.
6. Random IOPS cover the entire range of legal logical block addresses (LBAs). Measurements are performed on a full drive (all LBAs have valid content).

### 3.3 Electrical Characteristics

#### 3.3.1 Supply Voltage

**Table 6. Operating Voltage**

Description	Min	Max	Unit
Operating Voltage for 5 V (+/- 5%)	4.75	5.25	V

#### 3.3.2 Power Consumption

**Table 7. Typical Power Consumption**

Mode	Typ	Unit
Active	2.4	W
Idle	0.06	W



Drive will transition to idle power level once idle for 25 ms whether or not sleep or standby command is received. Standby power levels assume DIPM enabled. Active power is measured on an IOMeter workload of full bandwidth 64 K sequential writes with queue depth 1.

## 3.4 Environmental Conditions

### 3.4.1 Temperature

**Table 8. Temperature Related Specifications**

	Mode	Min	Typ	Max	Unit
Ambient Temperature	Operating	0		70	°C
	Non-Operating	-55		95	°C
Temperature Gradient	Operating		20		°C/hr *
	Non-Operating		30		°C/hr *
Humidity	Operating	5		95	%
	Non-Operating	5		95	%

**Note:** without condensation.

### 3.4.2 Altitude

The drive is not sensitive to changes in altitude because it has no moving parts. Drive tested between -1K and 40K feet.

### 3.4.3 Shock and Vibration

**Table 9. Shock and Vibration Specifications**

	Mode	Timing	Max	Unit
Shock <sup>1</sup>	Operating	at 0.5 msec	1,000	G
	Non-Operating	at 0.5 msec	1,000	G
Vibration <sup>2</sup>	Operating		2.17 G	7-800 Hz
	Non-Operating		3.13 G	10-500 Hz <sup>3</sup>

**Notes:**

- Shock specifications assumes that the SSD is mounted securely with the input vibration applied to the drive mounting screws. Stimulus may be applied in the X, Y or Z axis.
- Vibration specifications assumes that the SSD is mounted securely with the input vibration applied to the drive mounting screws. Stimulus may be applied in the X, Y or Z axis.
- Sine wave sweeping 1 oct/min.

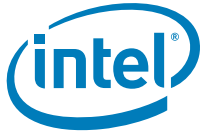

### 3.4.4 Acoustics

The drive has no moving or noise-emitting parts; therefore, it produces negligible sound (0 dB) in all modes of operation.

### 3.4.5 Electromagnetic Immunity

Electromagnetic Immunity tests assume the SSD is properly installed in the representative host system. The drive will operate properly without errors or degradation in performance when subjected to radio frequency (RF) environments defined in the following table:

Table 10. Electromagnetic Immunity Specifications

Test	Description	Performance Criteria	Reference Standard
Electrostatic discharge	Contact, HCP, VCP: ±8 kV; Air: ± 15 kV	B	EN 61000-4-2: 1995
Radiated RF immunity	80 to 1,000 MHz, 3 V/m, 80% AM with 1 kHz sine 900 MHz, 3 V/m, 50% pulse modulation at 200 Hz	A	EN 61000-4-3: 1996 ENV 50204: 1995
Electrical fast transient	± 1 kV on AC mains, ± 0.5 kV on external I/O	B	EN 61000-4-4: 1995
Surge immunity	± 1 kV differential, ± 2 kV common, AC mains	B	EN 61000-4-5: 1995
Conducted RF immunity	150 kHz to 80 MHz, 3 Vrms, 80% AM with 1 kHz sine	A	EN 61000-4-6: 1996
Voltage dips, interrupts	0% open, 5 seconds 0% short, 5 seconds 40%, 0.10 seconds 70%, 0.01 seconds	C C C B	EN 61000-4-11: 1994

**Notes:**

- Performance Criteria A** = The device shall continue to operate as intended, i.e., normal unit operation with no degradation of performance.
- Performance Criteria B** = The device shall continue to operate as intended after completion of the test. However, during the test, some degradation of performance is allowed as long as there is no data loss operator intervention to restore device function.
- Performance Criteria C** = temporary loss of function is allowed. Operator intervention is acceptable to restore device function.
- Electrostatic Discharge applied to drive enclosure.

## 3.5 Reliability

Table 11. Reliability Specifications

Parameter	Value
Nonrecoverable read errors (BER)	1 sector in 10 <sup>15</sup> bits read, max
Mean Time Between Failures (MTBF)	2,000,000 hours
Power On/Off Cycles	50,000 cycles

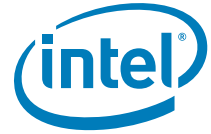

### **3.5.1 Non-recoverable read errors**

The nonrecoverable read error rate will not exceed one sector in the specified number of bits read. In the extremely unlikely event of a nonrecoverable read error, the drive will report it as a read failure to the host; the sector in error is considered corrupt and is not returned to the host.

### **3.5.2 Mean Time Between Failure**

The Mean Time Between Failures (MTBF) is calculated based on a Part Stress Analysis. It assumes nominal voltage, with all other parameters within specified range.

### **3.5.3 Power On/Off Cycles**

Defined as power being removed from the drive, and then restored. Note that host systems and drive enclosures may remove power from the drive for reasons other than a system shutdown.

## 4.0 Mechanical Information

Figure 2. Dimensions

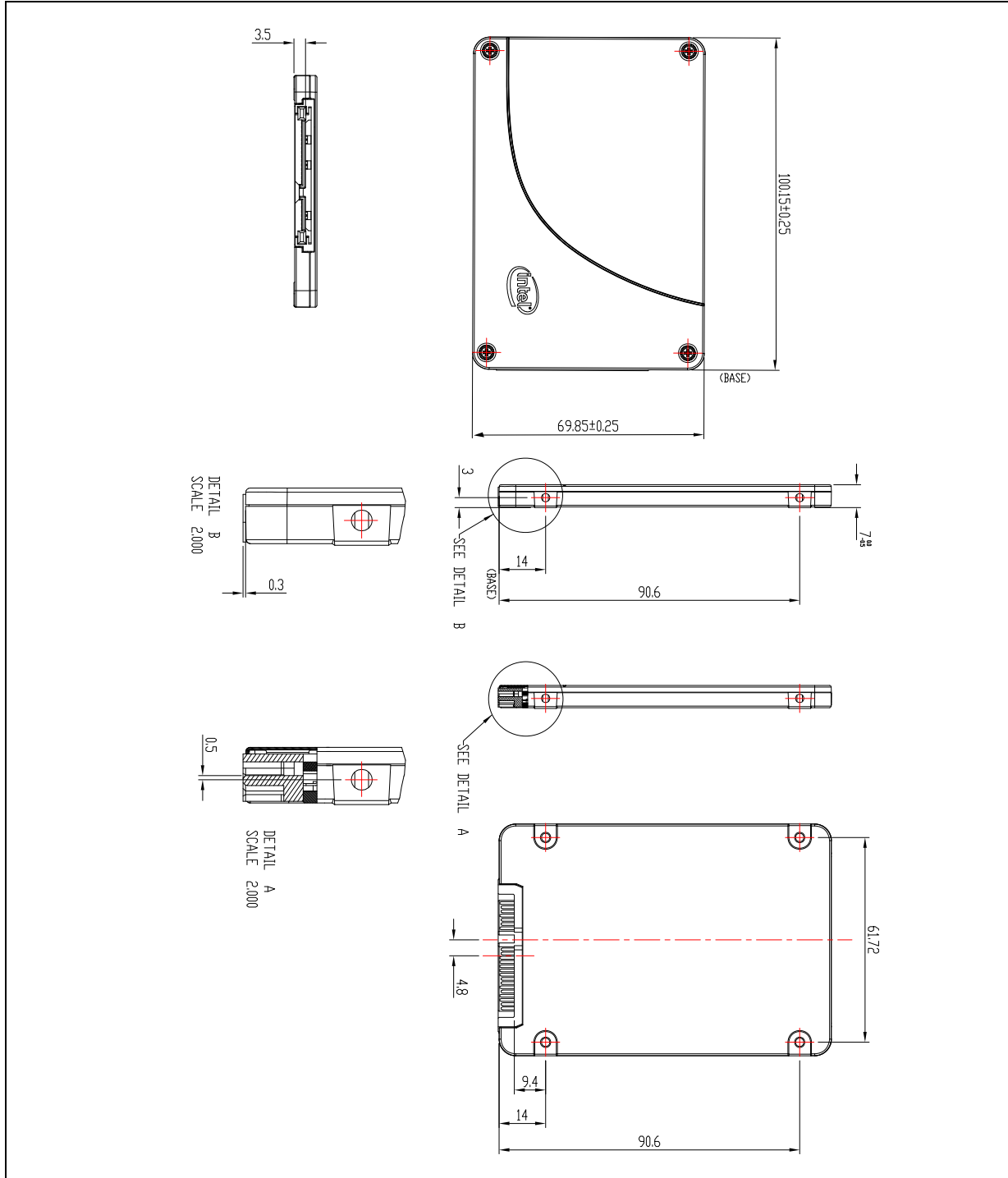

**Note:** All dimensions are in millimeters.



## 5.0 Pin and Signal Descriptions

This section identifies the pin locations and signal descriptions of the Intel High Performance SSDs.

### 5.1 Pin Locations

Figure 3. Layout of Signal and Power Segment Pins

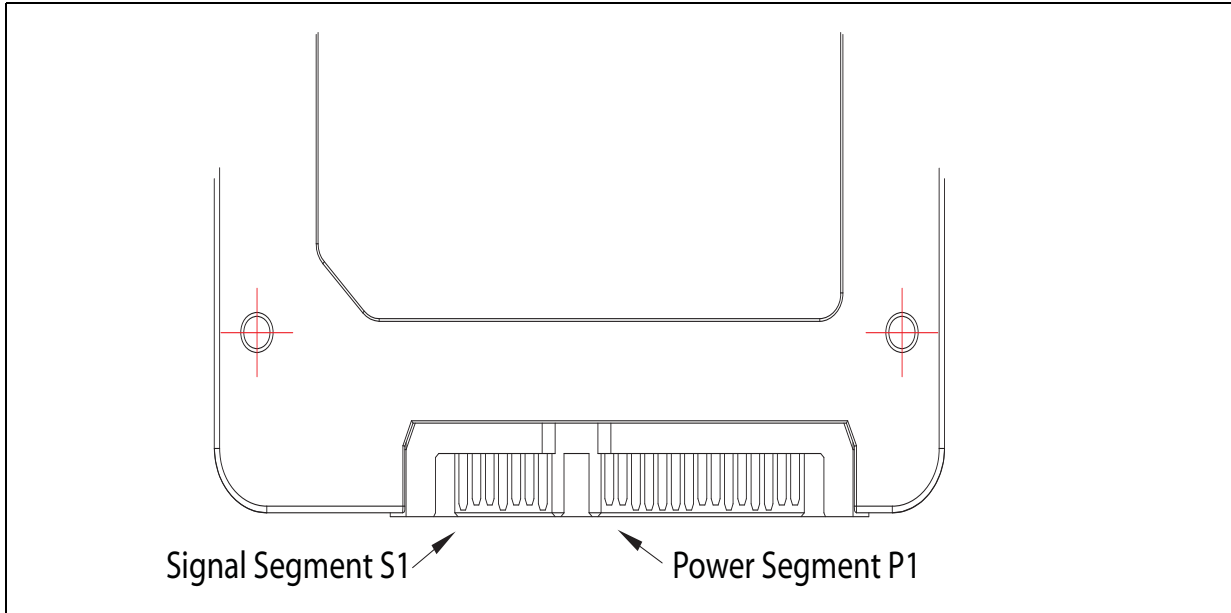

### 5.2 Signal Description Table

Table 12. Serial ATA Connector Pin Signal Definitions

Pin	Function	Definition
S1	Ground	2nd mate
S2	A+	Differential signal pair A
S3	A-	
S4	Ground	2nd mate
S5	B-	Differential signal pair B
S6	B+	
S7	Ground	2nd mate

**Note:** Key and spacing separate signal and power segments.



Table 13. Serial ATA Power Pin Definitions

Pin <sup>1</sup>	Function	Definition	Mating Order
P1	Not connected. <sup>2</sup>	3.3 V Power	2nd Mate
P2	Not connected <sup>2</sup> .	3.3 V Power	2nd Mate
P3	Not connected. <sup>2</sup>	3.3 V Power	1st Mate
P4	Ground <sup>3, 4</sup>		1st Mate
P5	Ground <sup>3</sup>		1st Mate
P6	Ground <sup>3</sup>		1st Mate
P7	V <sub>5</sub> <sup>3, 5</sup>	5 V Power	1st Mate
P8	V <sub>5</sub> <sup>3, 5</sup>	5 V Power	2nd Mate
P9	V <sub>5</sub> <sup>3, 5</sup>	5 V Power	2nd Mate
P10	Ground <sup>3</sup>		1st Mate
P11	DAS <sup>6</sup>	Device Activity Signal <sup>6</sup>	2nd Mate
P12	Ground <sup>3, 4</sup>		1st Mate
P13	Not connected. <sup>7</sup>	12 V Power	2nd Mate
P14	Not connected. <sup>7</sup>	12 V Power	2nd Mate
P15	Not connected. <sup>7</sup>	12 V Power	2nd Mate

**Notes:**

- All pins are in a single row, with a 1.27 mm (0.050") pitch.
- Pins P1, P2 and P3 are connected together, although they are not connected internally to the device. The host may put 3.3 V on these pins.
- The mating sequence is:
  - the ground pins P4-P6, P10, P12 and the 5v power pin P7.
  - the signal pins and the rest of the 5V power pins P8-P9.
- Ground connectors P4 and P12 may contact before the other 1st mate pins in both the power and signal connectors to discharge ESD in a suitably configured backplane connector.
- Power pins P7, P8, and P9 are internally connected to one another within the device.
- The host may ground P11 if it is not used for Device Activity Signal (DAS).
- Pins P13, P14 and P15 are connected together, although they are not connected internally to the device. The host may put 12 V on these pins.

## 5.3 Hot Plug Support

Hot Plug insertion and removal are supported in the presence of a proper connector and appropriate operating system (OS) support as described in the SATA 2.6 specification. This product supports Asynchronous Signal Recovery and will issue an unsolicited COMINIT when first mated with a powered connector to guarantee reliable detection by a host system without hardware device detection.



## 6.0 Command Sets

### 6.1 ATA Commands

The Intel X25-E SATA SSD supports all the mandatory ATA commands defined in the ATA/ATAPI-7 specification.

#### 6.1.1 ATA General Feature Command Set

The Intel X25-E SATA SSD supports the ATA General Feature command set (non-PACKET), which consists of

- EXECUTE DEVICE DIAGNOSTIC
- FLUSH CACHE
- IDENTIFY DEVICE
- READ DMA
- READ SECTOR(S)
- READ VERIFY SECTOR(S)
- SEEK
- SET FEATURES
- WRITE DMA
- WRITE SECTOR(S)
- READ MULTIPLE
- SET MULTIPLE MODE
- WRITE MULTIPLE

The Intel X25-E SATA SSD also supports the following optional commands:

- READ BUFFER
- WRITE BUFFER
- NOP
- DOWNLOAD MICROCODE

##### 6.1.1.1 IDENTIFY DEVICE Data

The following table details the sector data returned after issuing an IDENTIFY DEVICE command.

**Table 14. Returned Sector Data**

Word	F = Fixed V = Variable X = Both	Default Value	Description
0	F	0040h	General configuration bit-significant information
1	X	3FFFh	Obsolete - Number of logical cylinders (16,383)
2	V	C837h	Specific configuration



Table 14. Returned Sector Data (Continued)

Word	F = Fixed V = Variable X = Both	Default Value	Description
3	X	0010h	Obsolete - Number of logical heads (16)
4-5	X	0h	Retired
6	X	003Fh	Obsolete - Number of logical sectors per logical track (63)
7-8	V	0h	Reserved for assignment by the CompactFlash Association
9	X	0h	Retired
10-19	F	Varies	Serial number (20 ASCII characters)
20-21	X	0h	Retired
22	X	0h	Obsolete
23-26	F	Varies	Firmware revision (8 ASCII characters)
27-46	F	Varies	Model number (Intel Solid State Drive)
47	F	8010h	7:0—Maximum number of sectors transferred per interrupt on MULTIPLE commands
48	F	0h	Reserved
49	F	2F00h	Capabilities
50	F	4000h	Capabilities
51-52	X	0h	Obsolete
53	F	0007h	Words 88 and 70:64 Valid
54	X	3FFFh	Obsolete - Number of logical cylinders (16,383)
55	X	0010h	Obsolete - Number of logical heads (16)
56	X	003Fh	Obsolete - Number of logical sectors per logical track (63)
57-58	X	00FBFC10h	Obsolete
59	F	0110h	Number of sectors transferred per interrupt on MULTIPLE commands
60-61	F	03B9ACA0h	Total number of user addressable sectors
62	X	0h	Obsolete
63	F	0007h	Multi-word DMA modes supported/selected
64	F	0003h	PIO modes supported
65	F	0078h	Minimum Multiword DMA transfer cycle time per word
66	F	0078h	Manufacturer's recommended Multiword DMA transfer cycle time
67	F	0078h	Minimum PIO transfer cycle time without flow control
68	F	0078h	Minimum PIO transfer cycle time with IORDY flow control
69-70	F	0h	Reserved (for future command overlap and queuing)
71-74	F	0h	Reserved for the IDENTIFY PACKET DEVICE command.
75	F	001Eh	Queue depth
76	F	0106h	Serial ATA capabilities
77	F	0h	Reserved for future Serial ATA definition
78	F	0048h	Serial ATA features supported
79	V	0040h	Serial ATA features enabled
80	F	00FCh	Major Version Number
81	F	001Ah	Minor Version Number
82	F	746Bh	Command set supported.

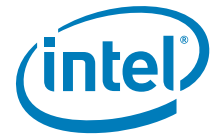

Table 14. Returned Sector Data (Continued)

Word	F = Fixed V = Variable X = Both	Default Value	Description
83	F	7C01h	Command sets supported.
84	F	6163h	Command set/feature supported extension.
85	V	7069h	Command set/feature enabled.
86	V	BC01h	Command set/feature enabled.
87	V	6163h	Command set/feature default.
88	V	407Fh	Ultra DMA Modes
89	F	0001h	Time required for security erase unit completion
90	F	0001h	Time required for Enhanced security erase completion
91	V	0h	Current advanced power management value
92	V	FFFEh	Master Password Revision Code
93	F	0h	Hardware reset result. The contents of bits (12:0) of this word shall change only during the execution of a hardware reset.
94	V	0h	Vendor's recommended and actual acoustic management value.
95	F	0h	Stream Minimum Request Size
96	V	0h	Streaming Transfer Time - DMA
97	V	0h	Streaming Access Latency - DMA and PIO
98-99	F	0h	Streaming Performance Granularity
100-103	V	03B9ACA0h	Maximum user LBA for 48-bit Address feature set.
104	V	0h	Streaming Transfer Time - PIO
105	F	0h	Reserved
106	F	0h	Physical sector size / Logical Sector Size
107	F	0h	Inter-seek delay for ISO-7779 acoustic testing in microseconds
108-111	F	Varies	Unique ID
112-115	F	0h	Reserved for world wide name extension to 128 bits
116	V	0h	Reserved for technical report
117-118	F	0h	Words per Logical Sector
119	F	401Ch	Supported Settings
120	F	401Ch	Command Set/Feature Enabled/Supported
121-126	F	0h	Reserved
127	F	0h	Removable Media Status Notification feature set support
128	V	0021h	Security status
129-159	X	0h	Vendor specific
160	F	0h	CompactFlash Association (CFA) power mode 1
161-175	X	0h	Reserved for assignment by the CFA
176-205	V	0h	Current media serial number
206-216	F	0h	Reserved

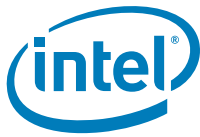

Table 14. Returned Sector Data (Continued)

Word	F = Fixed V = Variable X = Both	Default Value	Description
217	F	0001h	Non-rotating media device
218-221	F	0h	Reserved
222	F	101Fh	Reserved
223-233	F	0h	Reserved
234	F	0001h	Reserved
235	F	02A0h	Reserved
255	X	Varies	Integrity word (Checksum and Signature)

**Notes:**

1. **F = Fixed.** The content of the word is fixed and does not change. For removable media devices, these values may change when media is removed or changed.
2. **V = Variable.** The state of at least one bit in a word is variable and may change depending on the state of the device or the commands executed by the device.
3. **X = F or V.** The content of the word may be fixed or variable.

### 6.1.2 Power Management Command Set

The Intel X25-E SATA SSD supports the Power Management command set, which consists of

- CHECK POWER MODE
- IDLE
- IDLE IMMEDIATE
- SLEEP
- STANDBY
- STANDBY IMMEDIATE

### 6.1.3 Security Mode Feature Set

The Intel X25-E SATA SSD supports the Security Mode command set, which consists of

- SECURITY SET PASSWORD
- SECURITY UNLOCK
- SECURITY ERASE PREPARE
- SECURITY ERASE UNIT
- SECURITY FREEZE LOCK
- SECURITY DISABLE PASSWORD

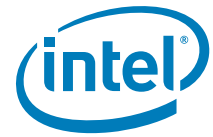

#### 6.1.4 SMART Command Set

The Intel X25-E SATA SSD supports the SMART command set, which consists of

- SMART ENABLE OPERATIONS
- SMART DISABLE OPERATIONS
- SMART ENABLE/DISABLE AUTOSAVE
- SMART RETURN STATUS

The Intel X25-E SATA SSD also supports the following optional commands:

- SMART EXECUTE OFF-LINE IMMEDIATE
- SMART READ ATTRIBUTE THRESHOLDS
- SMART READ DATA
- SMART READ LOG
- SMART WRITE LOG

#### 6.1.5 Host Protected Area Command Set

The Intel X25-E SATA SSD supports the Host Protected Area command set, which consists of

- READ NATIVE MAX ADDRESS
- SET MAX ADDRESS
- READ NATIVE MAX ADDRESS EXT
- SET MAX ADDRESS EXT

The Intel X25-E SATA SSD also supports the following optional commands:

- SET MAX SET PASSWORD
- SET MAX LOCK
- SET MAX FREEZE LOCK
- SET MAX UNLOCK

#### 6.1.6 48-Bit Address Command Set

The Intel X25-E SATA SSD supports the 48-bit Address command set, which consists of

- FLUSH CACHE EXT
- READ DMA EXT
- READ NATIVE MAX ADDRESS EXT
- READ SECTOR(S) EXT
- READ VERIFY SECTOR(S) EXT
- SET MAX ADDRESS EXT
- WRITE DMA EXT
- WRITE MULTIPLE EXT
- WRITE SECTOR(S) EXT



### 6.1.7 Device Configuration Overlay Command Set

The Intel X25-E SATA SSD supports the Device Configuration Overlay command set, which consists of

- DEVICE CONFIGURATION FREEZE LOCK
- DEVICE CONFIGURATION IDENTITY
- DEVICE CONFIGURATION RESTORE
- DEVICE CONFIGURATION SET

### 6.1.8 General Purpose Log Command Set

The Intel X25-E SATA SSD supports the General Purpose Log command set, which consists of

- READ LOG EXT
- WRITE LOG EXT

## 6.2 SATA Commands

The SATA 2.6 specification is a super set of the ATA/ATAPI-7 specification with regard to supported commands. The Intel X25-E SATA SSD supports the following features that are unique to the SATA specification.

### 6.2.1 Software Settings Preservation

The Intel X25-E SATA SSD supports the SET FEATURES parameter to enable/disable the preservation of software settings.

### 6.2.2 Native Command Queuing

The Intel X25-E SATA SSD supports the Native Command Queuing (NCQ) command set, which consists of

- READ FPDMA QUEUED
- WRITE FPDMA QUEUED

**Note:**

1. With a maximum queue depth equal to 31

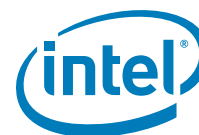

## 7.0 References

This document references standards defined by a variety of organizations. Use the following list to identify the location of an organization's standards information.

**Table 15. Standards References**

Date or Rev. #	Title	Location
July 2007	RoHS	Search for material data declaration sheets at <a href="http://intel.pcnalert.com">http://intel.pcnalert.com</a>
July 2007	SFF-8144, 1.8" drive form factor	<a href="http://www.sffcommittee.org">http://www.sffcommittee.org</a>
June 2007	Intel Matrix Storage Manager	<a href="http://support.intel.com/support/chipsets/imsm/">http://support.intel.com/support/chipsets/imsm/</a>
February 2007	Serial ATA Revision 2.6	<a href="http://www.sata-io.org">http://www.sata-io.org</a>
May 2006	SFF-8223, 2.5" Drive w/Serial Attachment Connector	<a href="http://www.sffcommittee.org">http://www.sffcommittee.org</a>
May 2005	SFF-8201, 2.5" drive form factor	<a href="http://www.sffcommittee.org">http://www.sffcommittee.org</a>
April 2004	ATA-6 spec	<a href="http://www.t13.org/project/d1410r3b-ATA-ATAPI-6.pdf">http://www.t13.org/project/d1410r3b-ATA-ATAPI-6.pdf</a>
April 2004	ATA-7 Volume 1	<a href="http://www.t13.org/Documents/UploadedDocuments/docs2007/D1532v1r4b-AT_Attachment_with_Packet_Interface_-_7_Volume_1.pdf">http://www.t13.org/Documents/UploadedDocuments/docs2007/D1532v1r4b-AT_Attachment_with_Packet_Interface_-_7_Volume_1.pdf</a>
1995 1996 1995 1995 1996 1994	International Electrotechnical Commission EN 61000- 4-2 Electromagnetic compatibility (EMC) Part 4: Testing and Measurement Techniques - Section 2: Electrostatic Discharge Immunity Test 4-3 Electromagnetic compatibility (EMC) Part 4: Testing and Measurement Techniques - Section 3: Radiated, Radio Frequency, Electromagnetic Field Immunity Test 4-4 Electromagnetic compatibility (EMC) Part 4: Testing and Measurement Techniques - Section 4: Electrical Fast Transient/Burst Immunity Test 4-5 Electromagnetic compatibility (EMC) Part 4: Testing and Measurement Techniques - Section 5: Surge Immunity Test 4-6 Electromagnetic compatibility (EMC) Part 4: Testing and Measurement Techniques - Section 6: Immunity to Conducted Disturbances, Induced by Radio-Frequency Fields 4-11 Electromagnetic compatibility (EMC) Part 4: Testing and Measurement Techniques - Section 11: Voltage Dips, Short Interruptions and Voltage Variations Immunity Tests	<a href="http://www.iec.ch">http://www.iec.ch</a>



## 8.0 Glossary

This document incorporates many industry- and device-specific words. Use the following list to define a variety of terms and acronyms.

**Table 16. Glossary of Terms and Acronyms**

Term	Definition
ATA	Advanced Technology Attachment
ATAPI	Advanced Technology Attachment Packet Interface
BER	Bit error rate, or percentage of bits that have errors relative to the total number of bits received
DIPM	Device Initiated Link Power Management. The ability of the device to request SATA link power state changes.
DMA	Direct Memory Access
EXT	Extended
FP	First Party
GB	Giga-byte defined as $1 \times 10^9$ bytes
HDD	Hard Disk Drive
Hot Plug	A term used to describe the removal or insertion of a SATA hard drive when the system is powered on.
iMSM	The Intel Matrix Storage Manager device driver and associated system software.
LBA	Logical Block Address
MB	Mega-bytes defined as $1 \times 10^6$ bytes
MTBF	Mean time between failures
NCO	Native Command Queuing. The ability of the SATA hard drive to queue and re-order commands to maximize execution efficiency.
NOP	No Operation
OS	Operating System
Port	The point at which a SATA drive physically connects to the SATA controller.
RMS	Root Mean Squared
RPM	Revolutions Per Minute
SAS	Serial Attached SCSI
SATA	Serial ATA
SFF	Small Form Factor
SMART	Self-Monitoring, Analysis and Reporting Technology: an open standard for developing hard drives and software systems that automatically monitors a hard drive's health and reports potential problems.
SSD	Solid State Drive

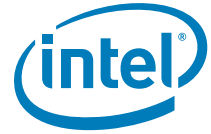

## 9.0 Revision History

Date	Revision	Description
July 2008	002	Updated the power number on <a href="#">page 1</a> and Table 7 on page 8 Updated standby shock spec on <a href="#">page 1</a> and <a href="#">Table 9 on page 9</a> Modified weight numbers on <a href="#">page 1</a> Updated Device decoder on <a href="#">page 2</a> Updated Random Write Speed on <a href="#">Table 4 on page 8</a> Update Sustained Sequential Read spec on <a href="#">page 1</a> and Table 3 on page 7 Changed maximum queue depth to 31 on 6.2.2 Updated Identify device information on 6.1.1.1 Added extra info on altitude in 3.4.2 RoHS link updated on <a href="#">Table 15 on page 21</a>
June 2008	001	Initial Release. Earlier information released as <i>Intel® Extreme Performance Solid State Drive Advance Product Manual - 318776-003US</i> .

